

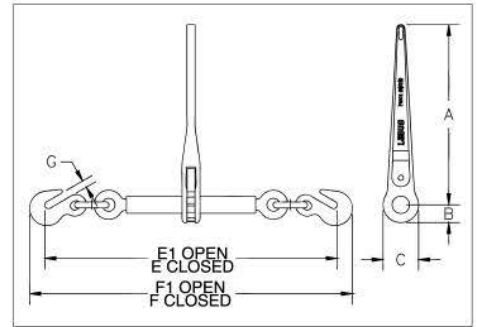

LOAD SECUREMENT COMPONENTS



Crosby LEBUS L-140



Load Rated

APPLICATION AND WARNING INFORMATION SECTION 17

- Upgraded for use with Grades 70, 80 and 100 Chain.
- Utilizes standard Crosby A-323 Alloy Eye Grab Hooks.
- New design one piece forged handle.
- Continuous take-up feature provides finite adjustment to tie down load.
- One piece assembly, no bolts or nuts to loosen.
- Ratchet spring is rust proofed.
- All load bearing or holding parts forged.
- Easy operating positive ratchet.
- Binders shown with Proof Loads have been individually proof tested to values shown, prior to shipment.
- Meets or exceeds requirements of US DOT FMCSA Part 393 Subpart I.
- Matches the Working Load Limit of Grade 100 chain except for 16mm size.

Crosby LEBUS L-140 Standard Ratchet Type Load Binders

| Model | Stock No. | Min-Max Chain Size (mm) | Working Load Limit (t) | Proof Load (kN) | Weight Each (kg) | Handle Length (mm) | Barrel Length (mm) | Take Up (mm) | Dimensions (mm) | | | | | | | |
|-------|-----------|-------------------------|------------------------|-----------------|------------------|--------------------|--------------------|--------------|-----------------|------|------|-----|-----|-----|-----|------|
| | | | | | | | | | A | B | C | E | E1 | F | F1 | G |
| R-7 | 1048404 | 8 - 10 | 3.99 | 79 | 5.49 | 356 | 254 | 203 | 356 | 35.1 | 70.0 | 583 | 786 | 638 | 842 | 12.7 |
| R-A | 1048422 | 10 - 13 | 6.80 | 134 | 6.66 | 356 | 254 | 203 | 356 | 35.1 | 70.0 | 641 | 845 | 702 | 905 | 16.0 |
| R-C | 1048440 | 13 - 16 | 7.26 | 143 | 6.60 | 356 | 254 | 203 | 356 | 35.1 | 70.0 | 670 | 873 | 748 | 951 | 18.3 |

3:1 Design Factor.

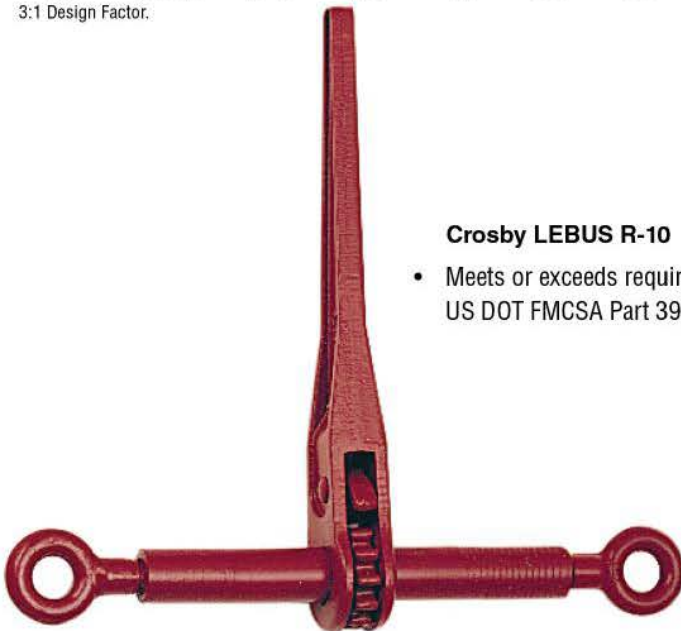

Crosby LEBUS R-10

- Meets or exceeds requirements of US DOT FMCSA Part 393 Subpart I.

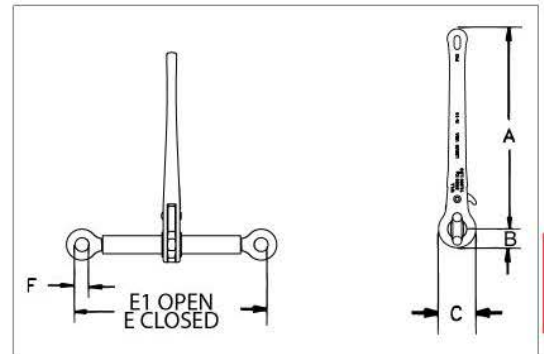

13

Crosby LEBUS R-10 Binder without Links and Hooks

| Model | Stock No. | Working Load Limit (t) | Weight Each (kg) | Handle Length (mm) | Barrel Length (mm) | Take Up (mm) | Dimensions (mm) | | | | | |
|-------|-----------|------------------------|------------------|--------------------|--------------------|--------------|-----------------|------|------|-----|-----|------|
| | | | | | | | A | B | C | E | E1 | F |
| R-10 | 1048468 | 7.26 | 3.65 | 356 | 254 | 203 | 356 | 35.1 | 70.0 | 356 | 559 | 25.4 |

3:1 Design Factor.



LOAD SECUREMENT COMPONENTS

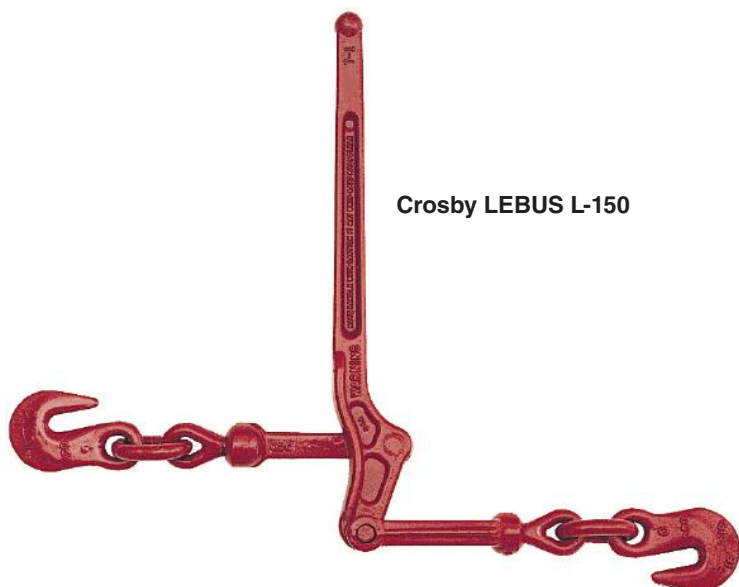

Crosby LEBUS L-150

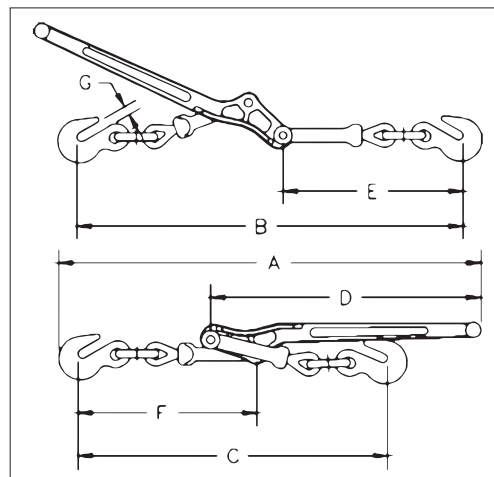

APPLICATION AND WARNING INFORMATION
SECTION 17

- Extra heavy construction at leverage point to prevent spreading. Heel of binder toggles away from load, permitting easy release.
- Ball and socket swivel joints at hook assemblies permit a straight line pull.
- Binders shown with Proof Loads have been individually proof tested to values shown, prior to shipment.
- Forged steel – Quenched & Tempered.
- Meets or exceeds requirements of US DOT FMCSA Part 393 Subpart I.

Crosby LEBUS L-150 Standard Lever Type Load Binders

| Model | Stock No. | Std. Pkg. | Min-Max Chain Size (mm) | Working Load Limit (t) | Proof Load (kN) | Ultimate Load (t) | Weight Each (kg) | Handle Length (mm) | Take Up (mm) | Dimensions (mm) | | | | | | |
|-------|-----------|-----------|-------------------------|------------------------|-----------------|-------------------|------------------|--------------------|--------------|-----------------|-----|-----|-----|-----|-----|------|
| | | | | | | | | | | A | B | C | D | E | F | G |
| 7-1 | 1048128 | 4 | 8 - 10 | 2.45 | 48 | 8.63 | 3.18 | 406 | 114 | 613 | 562 | 454 | 406 | 264 | 264 | 12.7 |
| A-1 | 1048146 | 4 | 10 - 13 | 4.17 | 82 | 15.0 | 5.66 | 475 | 114 | 730 | 654 | 540 | 475 | 313 | 314 | 16.0 |
| C-1 | 1048164 | 4 | 13 - 16 | 5.90 | 116 | 20.9 | 8.93 | 533 | 121 | 794 | 756 | 635 | 533 | 372 | 349 | 18.3 |



LOAD SECUREMENT COMPONENTS

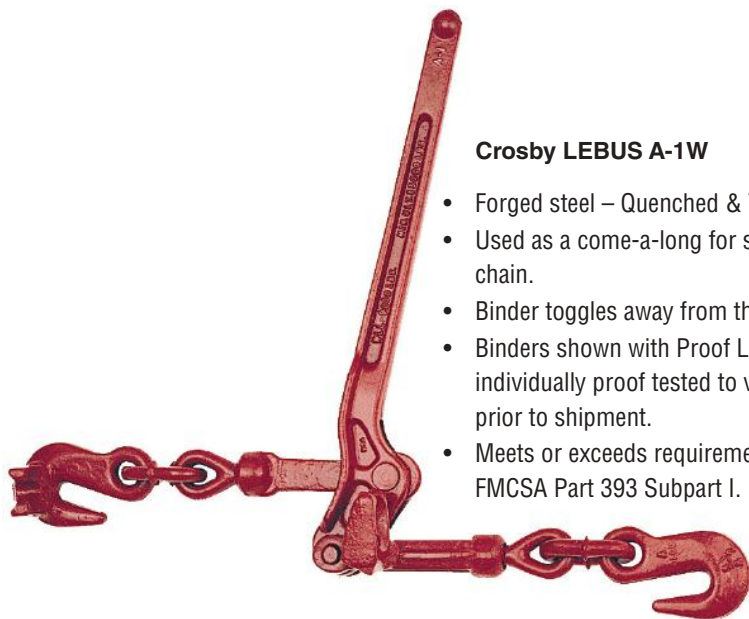

Crosby LEBUS A-1W

- Forged steel – Quenched & Tempered.
- Used as a come-a-long for short take-up on chain.
- Binder toggles away from the load.
- Binders shown with Proof Loads have been individually proof tested to values shown, prior to shipment.
- Meets or exceeds requirements of US DOT FMCSA Part 393 Subpart I.

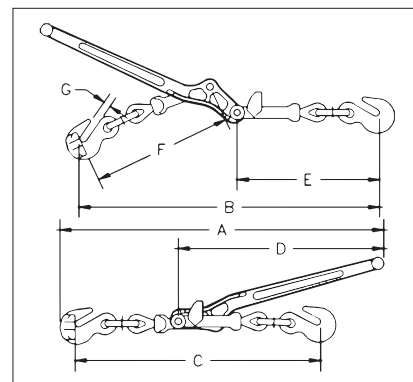

APPLICATION AND WARNING INFORMATION
SECTION 17

Crosby LEBUS A-1W Walking Load Binders

| Model | Stock No. | Chain Size (mm) | Working Load Limit (t) | Proof Load (kN) | Ultimate Load (t) | Weight Each (kg) | Handle Length (mm) | Dimensions (mm) | | | | | | |
|-------|-----------|-----------------|------------------------|-----------------|-------------------|------------------|--------------------|-----------------|-----|-----|-----|-----|-----|------|
| | | | | | | | | A | B | C | D | E | F | G |
| A-1W | 1048388 | 13 only | 4.17 | 82 | 15.0 | 5.94 | 475 | 730 | 654 | 540 | 475 | 313 | 314 | 16.0 |

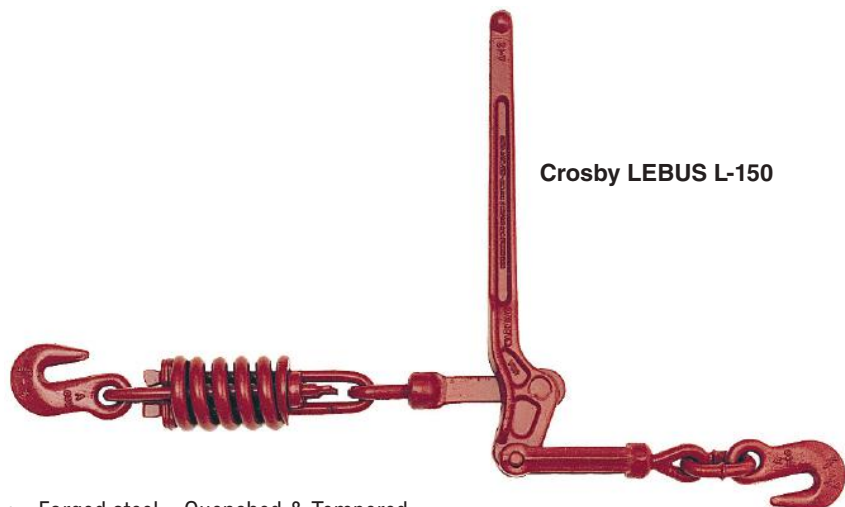

Crosby LEBUS L-150

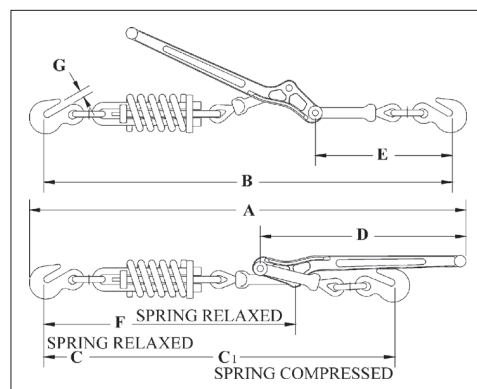

- Forged steel – Quenched & Tempered.
- Spring cushion for load protection, cushions shock and sway.
- Binder toggles away from the load.



APPLICATION AND WARNING INFORMATION
SECTION 17

Crosby LEBUS L-150 Snubbing Load Binders

| Model | Stock No. | Min-Max Chain Size (mm) | Working Load Limit (t) | Ultimate Load (t) | Weight Each (kg) | Handle Length (mm) | Take Up (mm) | Compression Strength of Spring (kg) | Dimensions (mm) | | | | | | | |
|-------|-----------|-------------------------|------------------------|-------------------|------------------|--------------------|--------------|-------------------------------------|-----------------|-----|-----|-----|-----|-----|-----|------|
| | | | | | | | | | A | B | C | C1 | D | E | F | G |
| 7-12 | 1048280 | 8 - 10 | 2.45 | 7.27 | 5.10 | 406 | 108 | 1040 | 832 | 781 | 711 | 673 | 406 | 264 | 483 | 12.7 |
| A-12 | 1048306 | 10 - 13 | 4.17 | 9.09 | 8.48 | 470 | 114 | 1500 | 945 | 864 | 749 | 773 | 475 | 313 | 530 | 16.0 |

Crosby LEBUS C-188 Spectrum 8®



- Heat treated alloy steel.
- Ends fitted with Crosby A-330 Quenched & Tempered alloy clevis grab hook.
- Finish – self colored.
- Meets or exceeds requirements of US DOT FMCSA Part 393 Subpart I.

Crosby LEBUS C-188 Spectrum 8® Alloy Boomer Chains

| Chain Size (mm) | Stock No. | Working Load Limit (kg) | Standard Length (m) | Weight Each (kg) |
|-----------------|-----------|-------------------------|---------------------|------------------|
| 10 | 279889 | 3200 | 6.10 | 13.7 |
| 13 | 279898 | 5400 | 6.10 | 24.5 |

Crosby LEBUS L-180



- Hooks are Forged – Quenched & Tempered.
- Individually Proof Tested.
- Spectrum 8® alloy steel from 20mm through 32mm (3/4" - 1-1/4").
- Meets or exceeds requirements of US DOT FMCSA Part 393 Subpart I.

Crosby LEBUS L-180 Winchline Tail Chain

| Wire Rope Diameter (mm)* | Stock No. | Working Load Limit (kg)† | Length (mm) | No. of Links | Weight Each (kg) |
|--------------------------|-----------|--------------------------|-------------|--------------|------------------|
| 8 - 10 | 1091473 | 2450 | 18 | 11 | 1.36 |
| 13 - 16 | 1091482 | 5900 | 18 | 7 | 2.81 |
| 19 - 22 | 1091511 | 15510 | 24 | 8 | 8.25 |
| 25 - 29 | 1091516 | 21640 | 18 | 5 | 9.60 |
| 25 - 29 | 1091525 | 21640 | 24 | 7 | 10.6 |
| 32 | 1091532 | 32795 | 24 | 5 | 18.1 |

* Recommended for IPS or XIP (EIP), RRL, FC or IWRC wire rope. † Ultimate Load is 3.5 times the Working Load Limit.

LOAD SECUREMENT COMPONENTS